

CHARLOTTA

S96-KOM4S/9/9

A	B	C	D	
1	S96-107	760	422	2/3
2	S96-108	760	422	2/3
3	S96-209	927	448	1/3
4	S96-210	905	435	1/3
5	S96-404	191	51	2/3
6	S96-406	655	51	2/3
7	S96-501	350	120	2/3
8	S96-502	350	120	2/3
9	S96-506	756	120	2/3
10	S96-550	117	117	1/3
11	S96-904	766	348	2/3
12	S96-9901	788	861	2/3

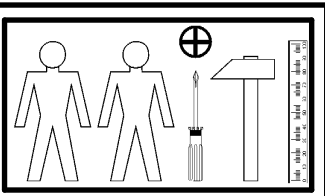
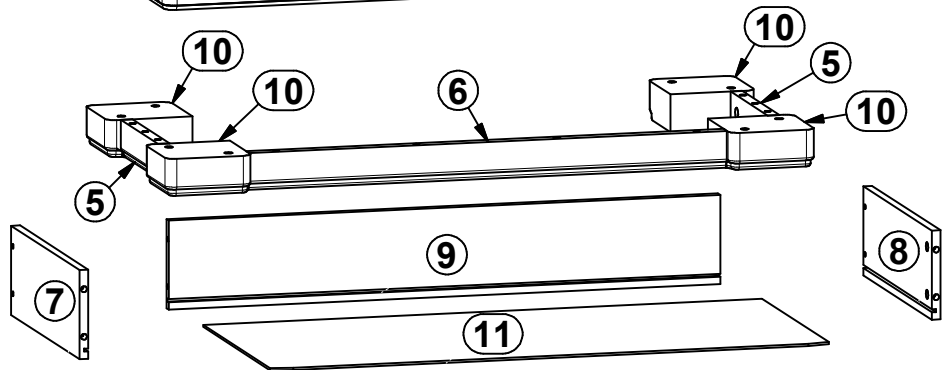
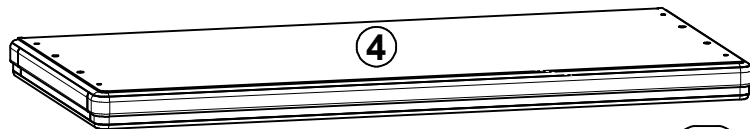
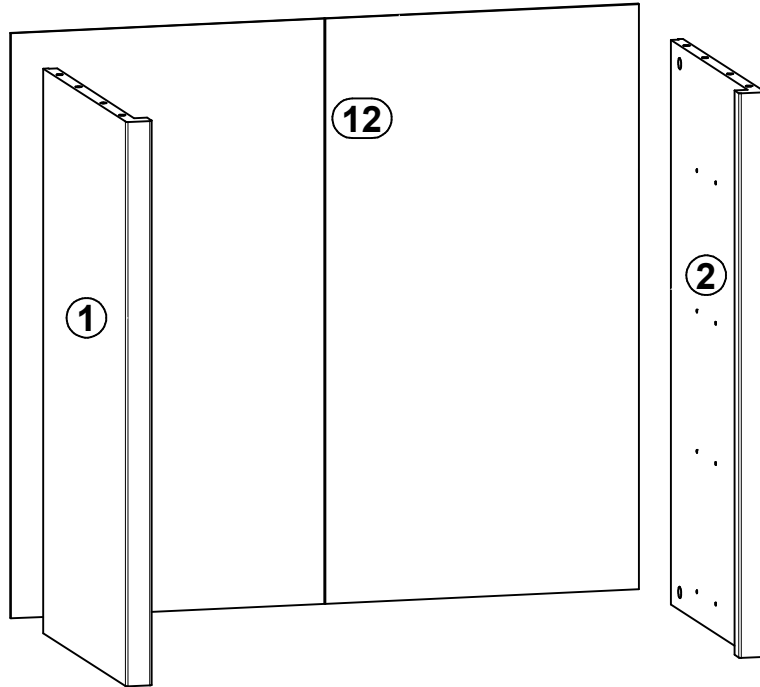
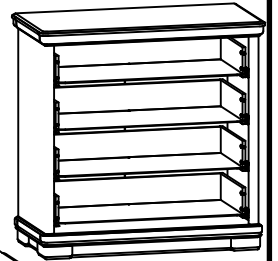

24x φ6x30 mm e16	12x φ8x30 mm f1	16x φ6.5x40 mm f25	8x φ10x40 mm f27	36x l1	8x φ3.5x16 mm p25	16x φ3x12 mm p54	14x φ1.5x12mm #16 r1	16x φ12x10.5mm #12 r15
30x r16	2x ø16 s2	4x 333 mm t19	24x h=18 mm w36	4x 350 mm w45\CL	4x 350 mm w45\CR	4x 350 mm w45\DL	4x 350 mm w45\DR	1x n26\1
1x φ3.5x16 mm p38	1x GLUE y1							

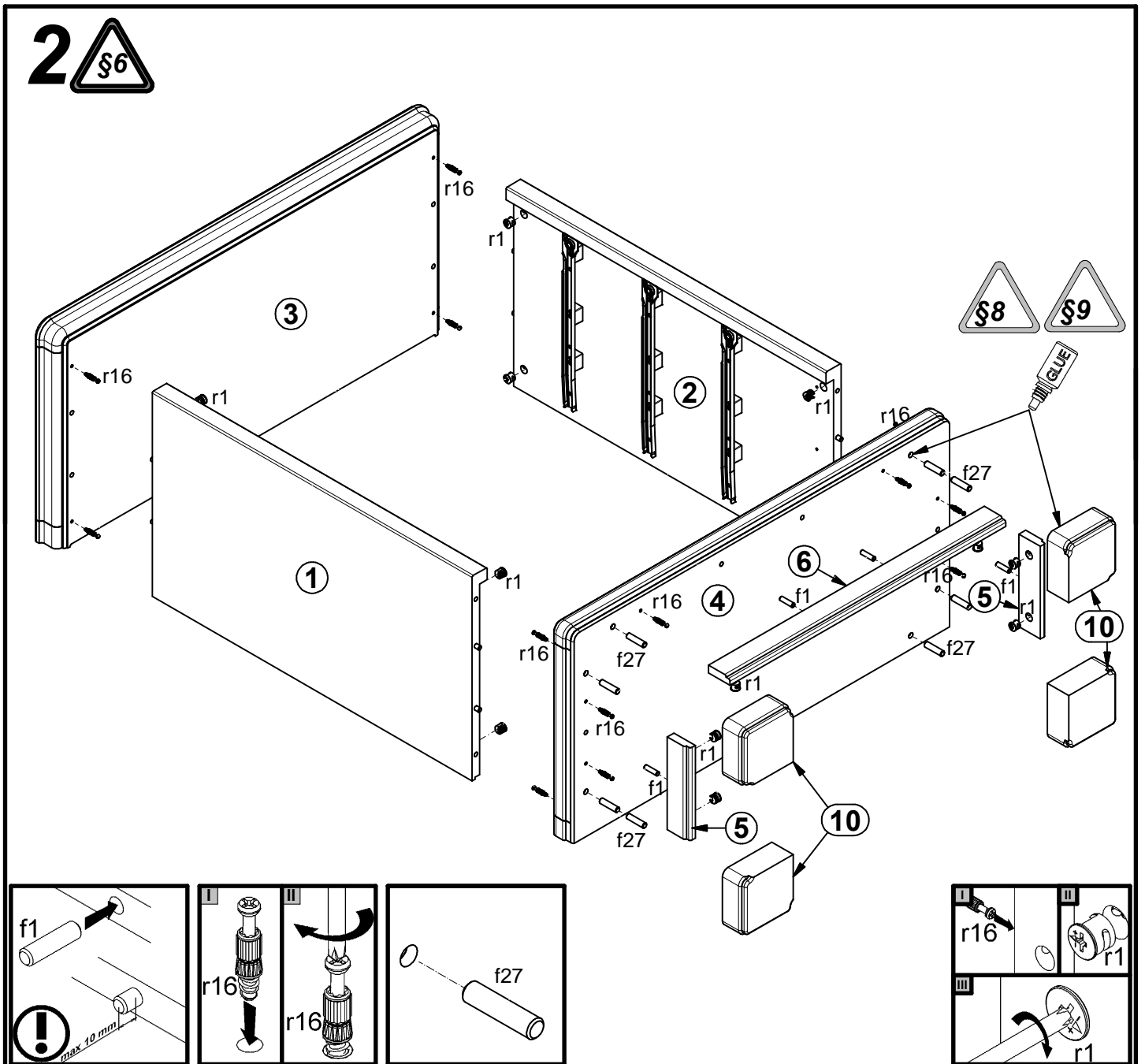
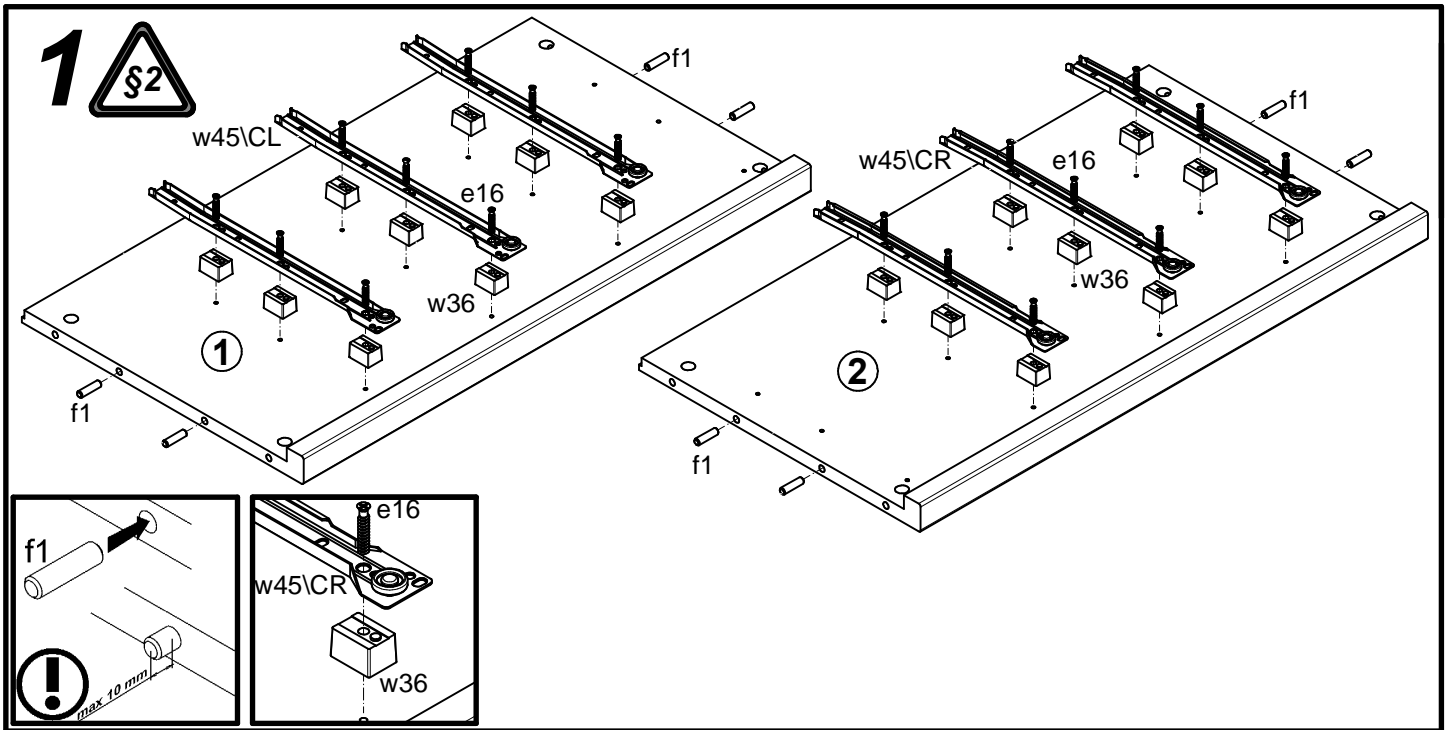

3

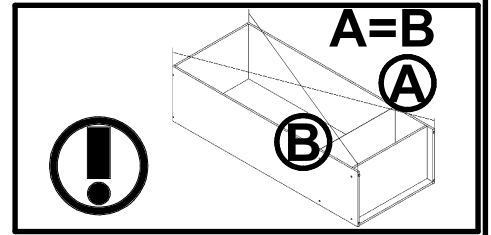
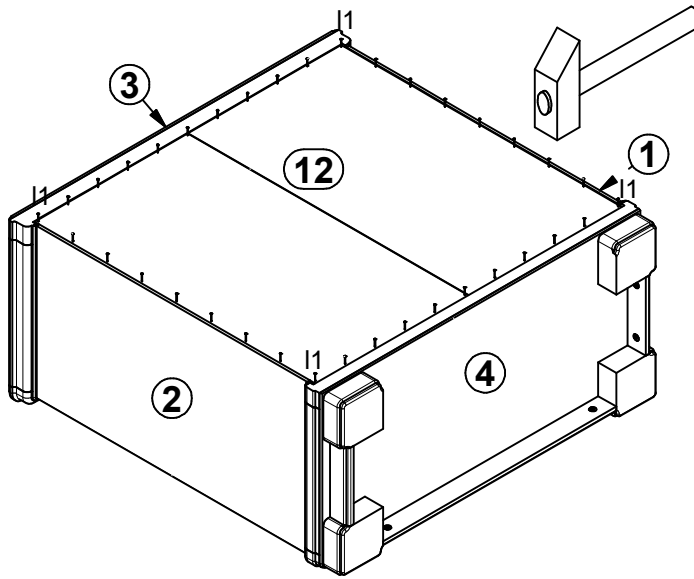

4

